



Ph.: 0361-2970214 (O)

OFFICE OF THE PRINCIPAL
HANDIQUE GIRLS' COLLEGE
GUWAHATI - 781001, ASSAM

Dr. Ranjit Sarma, M.Sc., M. Phil, Ph.D.
Principal-cum-Secretary

e-mail : hgcollege75@gmail.com
Website: www.hgcollege.edu.in

Ref. No. :

Date : 23-07-2025

SHORT NOTICE INVITING QUOTATION

No.: HGC/ESTT/NIQ/2025/273/005

Sealed quotations in the prescribed format as enclosed herewith with a non refundable court fee stamp of Rs. 8.25 are hereby invited from the reputed registered firms/contractors for **repair & renovation of existing 02 nos. of stair-cases- (1) Academic Building & (2) Zoology-Botany-Physics Department at Handique Girls' College, Guwahati-01, Assam.**

Terms and Conditions:

1. The sealed quotation along with all necessary documents as per the enclosed format is to be deposited at the designated Drop Box at College premises. Quotation not properly sealed will be liable for cancellation.
2. **Last date of submission of the quotation is 30th July, 2025.**
3. **All works mentioned in the Part-2 of the prescribed format must be completed within 01 month form the issuance of the Work Order.**
4. The Sealed quotation must be superscribed with the Quotation Number and addressed to the undersigned with the senders full address.
5. The estimated cost of the work is ₹ 2,72,100/- (Rupees two lakh seventy two thousand one hundred) only.
6. The bidders will have to submit the **Quotation Fee of Rs. 500/- (Rupees five hundred)** in the form of **Demand Draft** in favour of **"Principal Cum Secretary, Handique Girls' College"** payable at **Guwahati** along with the quotation.
7. The selected bidders will have to submit the **Earnest Money** of 2% of the estimated cost in the form of **Demand Draft** in favour of **"Principal Cum Secretary, Handique Girls' College"** payable at **Guwahati while receiving the work order.**
8. Quotation submitted by the bidder/s shall remain valid for acceptance for a period of 180 days from the date of opening of the quotations.
9. The bidder/s shall not be entitled to revoke or cancel his/their quotation or to vary any of the terms thereof during the aforesaid period of validity.
10. The period of liability shall be 12 (Twelve) months reckoned from the date of issue of completion certificate on actual completion of the work.
11. The authority reserves the right to cancel the work/tender partially or at whole without any reason thereto.
12. **All necessary deductions e.g. Security Deposit, GST, Income Tax, etc. will be deducted from the bill as per the norms of Govt. of Assam.**

R. Sarma

Principal
Handique Girls' College
Guwahati-01, Assam

Quotation for repair & renovation of existing 2 nos. of stair-cases- (1) Academic Building & (2) Zoology-Botany-Physics Department at Handique Girls' College, Guwahati

Quotation No. HGC/ESTT/NIQ/2025/273/005, dt.: 23/07/2025

Part 1 of 2

1. Name of Firm:

2. Full Postal Address:

3. Contact No.:

Alternate Contact No:

4. E-mail id:

5. Proprietor/Owner Name:

6. PAN No.:

(Enclose a self attested copy)

7. GST Registration No.:

(Enclose a self attested copy)

8. APWD/CPWD Registration No.

(Enclose a self attested copy)

9. Experiences, if any (only 3):

Sl. No.	Name of Work	Organization name and address	Date of commencement of Work & Completion of Work	Tendered amount	Final Billed Amount
1					
2					
3					

10. Whether Non-refundable court fee Attached/Pasted: Yes / No

11. **Demand Draft (DD)** details for **Quotation Fee**:

a. Bank Name:

b. DD No.:

Date:

c. Amount:

Date:

Signature and Seal of the Firm

**Quotation for repair & renovation of existing 2 nos. of stair-cases- (1) Academic Building
& (2) Zoology-Botany-Physics Department at Handique Girls' College, Guwahati
Quotation No. HGC/ESTT/NIQ/2025/273/005, dt.: 23/07/2025**

Part 2 of 2

(1) Repair & renovation of existing stair-cases- **Academic Building**

#	Description of Item	Qty	Units	Rate	Amount
1	Demolishing R.C.C. work manually/ by mechanical means including stacking of steel bars and disposal of unserviceable material within 50 metres lead as per direction of Engineer - in- charge	1.61	CUM		
2	Brick on edge flooring with bricks of class designation 7.5 on a bed of 12 mm cement mortar, including filling the joints with same mortar, with common burnt clay non modular bricks:				
	1:4 (1 cement : 4 coarse sand)	31.80	SQM		
3	Providing and laying cement concrete in kerbs, steps and the like at or near ground level excluding the cost of centering, shuttering and finishing.				
	1:1½:3 (1 Cement: 1½ coarse sand(zone-III) derived from natural sources : 3 graded stone aggregate 20 mm nominal size derived from natural sources)	0.80	SQM		
4	Providing and laying vitrified floor tiles in different sizes (thickness to be specified by the manufacturer) with water absorption less than 0.08% and conforming to IS: 15622, of approved make, in all colours and shades, laid on 20mm thick cement mortar 1:4 (1 cement : 4 coarse sand), jointing with grey cement slurry @ 3.3 kg/ sqm including grouting the joints with white cement and matching pigments etc., complete				
	Size of Tile 600x600 mm	64.34	SQM		
Total Amount-					

(2) Repair & renovation of existing stair-cases- **Zoology-Botany-Physics** Department:

#	Description of Item	Qty	Units	Rate	Amount
1	Demolishing R.C.C. work manually/ by mechanical means including stacking of steel bars and disposal of unserviceable material within 50 metres lead as per direction of Engineer - in- charge	2.12	CUM		
2	Providing and laying cement concrete in kerbs, steps and the like at or near ground level excluding the cost of centering, shuttering and finishing.				
	1:1½:3 (1 Cement: 1½ coarse sand(zone-III) derived from natural sources : 3 graded stone aggregate 20 mm nominal size derived from natural sources)	1.77	SQM		
3	Providing and laying vitrified floor tiles in different sizes (thickness to be specified by the manufacturer) with water absorption less than 0.08% and conforming to IS: 15622, of approved make, in all colours and shades, laid on 20mm thick cement mortar 1:4 (1 cement : 4 coarse sand), jointing with grey cement slurry @ 3.3 kg/ sqm including grouting the joints with white cement and matching pigments etc., complete				
	Size of Tile 600x600 mm	84.84	SQM		
Total Amount-					

Grand Total (1) + (2):

Grand total amount in words:

Date:

Signature and Seal of the Firm

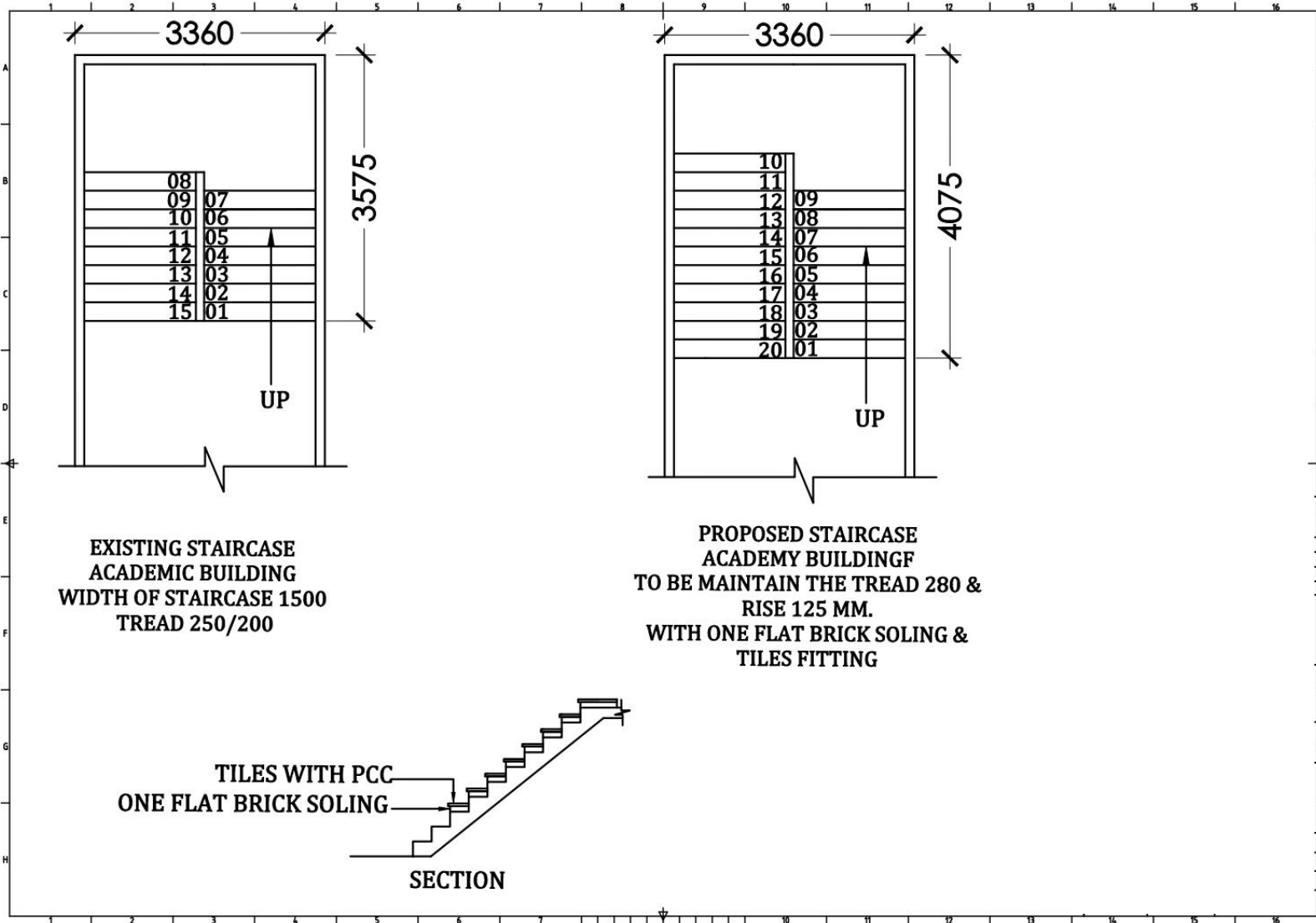

**EXISTING STAIRCASE
ACADEMIC BUILDING
WIDTH OF STAIRCASE 1500
TREAD 250/200**

**PROPOSED STAIRCASE
ACADEMY BUILDING
TO BE MAINTAIN THE TREAD 280 &
RISE 125 MM.
WITH ONE FLAT BRICK SOLING &
TILES FITTING**

TILES WITH PCC
ONE FLAT BRICK SOLING

SECTION

